

Single-cylinder Engine

Metal Assembly Model

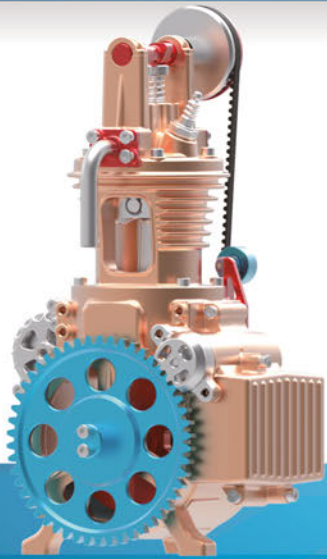

Structural features:

1. Single cylinder structure
2. Overhead camshaft valve control structure
3. Synchronous cam driving mode
4. Traditional crankshaft connecting rod system
5. Single intake and exhaust valves structure

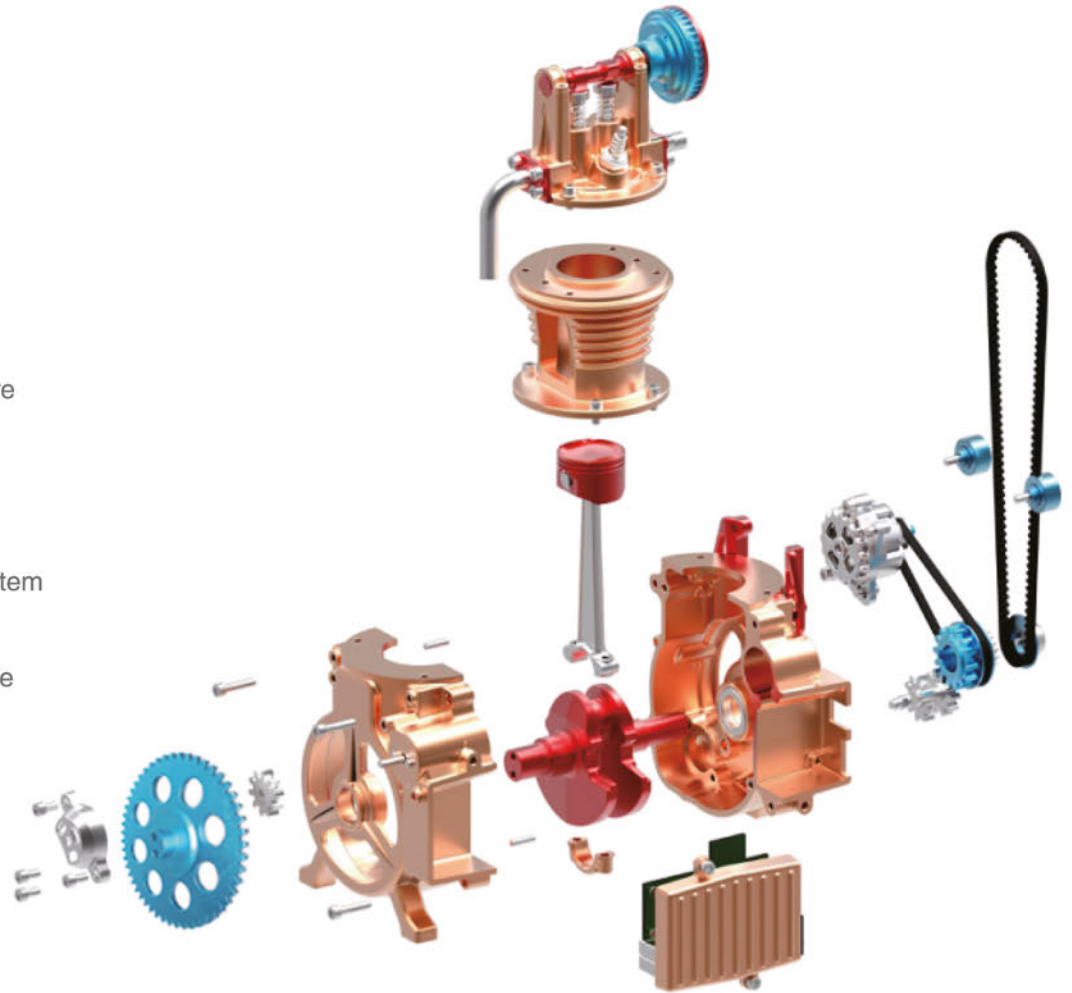

I–Make • Real Model • Real World

General information about product

I. Product Data

Product name: Single-cylinder engine (overhead camshaft type)

Product model: DM17-T

Main materials: Anodic aluminum oxide + stainless steel

Charging voltage: DC 5V

Battery capacity: 500mAh

Product standards: GB/T9254-2008

GB/T17626.2-2006

II. Product description

- ◆ Teching Craftsman series of products are metal structure assembly models. Its primary material is aluminum alloy with anodized surface, and the product structure is a real industrial structure;
- ◆ Assemble parts using various tools with the installation procedures and methods substantially compliant with practical industrial requirements;
- ◆ This series of products are principally designed to improve users' hands-on ability and concentration, and to develop habits of "preciseness and stress on discipline";
- ◆ Learn about various industrial machines, and study various industrial structures to improve user's capability of research and innovation.

III. Assembly Requirements

- ◆ Be sure to read the Basics of Standard Parts Assembly carefully to master basic standard parts assembly procedure and the usage of tools before assembly;
- ◆ The table shall be kept tidy and clean during assembly to prevent parts being lost or incorrectly assembled. Assemble parts in a rigorous and orderly fashion, view the diagrams carefully, and avoid incorrect assembly;
- ◆ Pay attention to the prompt text in instruction manual, carefully view the part installation orientation, and avoid incorrect comprehension. Pay attention to the requirements on testing;
- ◆ Lubricating oil shall be applied to friction areas to the greatest extent to prevent jamming during operation. Fastening screws must be thoroughly mounted to prevent looseness of parts;
- ◆ If you have any doubt when adjusting any assembly clearance or tightness after the completion of assembly, please refer to our website or WeChat public account;
- ◆ Users are encouraged to optimize the parts using material removing tools like files and sand paper with adult care where the personal safety is guaranteed;

- ◆ Users are encouraged to perform part modification or overall modification of model without potential safety hazard so as to develop modification capability as soon as possible;
- ◆ The user may disassemble this model and put it in the package again according to the parts list attached hereto;
- ◆ If any part is lost, please inquire of or purchase it from us (Teching official online store);
- ◆ The model structure is subject to continual improvement. If the real object differs from the instruction manual, please refer to our latest assembly information.
- ◆ Once the product fails to function due to battery failure, lubricating oil shortage or dust accumulation in product gaps because it is left unused for long, it's advisable to change the battery or disassemble and clean its parts.

Precautions

I. Safety Instruction

- ◆ Please read this manual carefully so that you are in a position to use this product correctly and safely;
- ◆ This series of products are industrial-level metal models, so its assembly and use requires certain safety awareness; improvement of safety awareness is also a function of the model;
- ◆ This model is suitable for users aged 14 and over. Please read this manual carefully for relevant safety information;
- ◆ Strictly prohibit children or pets swallowing or biting this product or its spare parts, since this may cause injury/damage;
- ◆ Use assembly tools rationally, assemble the parts in strict conformity with the instruction manual, and avoid forcible handling to avoid scratches; keep sharp points of tools or parts away from the eyes to avoid contusions;

- ◆ This model is made up of metallic parts mainly, and has a certain level of hardness and a certain weight; please place it properly to avoid bodily injuries; Protect the products and accessories against intense shock and vibration so as to avoid personal injury and product damage;
- ◆ During mechanical movement, do not put a finger or any other part of the body within the movement range to avoid contusions;
- ◆ Wire connectors must be connected according to the marks specified in the instruction manual to avoid short-circuit or failure arising from wrong connection;
- ◆ Charge, discharge and place the battery as required; it is advised to replace the battery when it has not been used for 3 months or more;
- ◆ Do not prevent any part from running forcibly in any form; to do this, turn off the power directly;
- ◆ To refit this model, please pay attention to the relevant part parameters, and avoid using any high-power electric part or device that may result in an accident.
- ◆ Please use parts of this product properly as per instruction manual. Don't use them for other purposes.

II. Battery and charging precautions

- ◆ This product is delivered with dedicated charging cable. Users shall use their own power adapters; output DC voltage: 5V; output DC current $\geq 1200\text{mA}$;
- ◆ Please make sure the contact is dry and free of dirt before charging. Please don't charge the battery if the product is not in use or is in repair;
- ◆ Don't put the battery in fire or have it exposed to sunlight, fire or similar excessively hot environment, since this may lead to leakage, excessively high temperature, bursting or ignition of battery;
- ◆ If improper change of battery may cause explosion, the battery must be replaced with one of identical or equivalent type;

- ◆ Never disassemble, squeeze, heat and set fire to the lithium battery delivered with this product, and never touch and pry the battery using any sharp object or screwdriver, etc., since this may cause the battery to ignite or burn;
- ◆ In the case of excessively high temperature, discoloration, bulging, leakage and other anomalies during the use, charging or keeping of battery, please take it out of service and change it with a new one to avoid safety problem;
- ◆ Since the battery temperature rises when it's being charged, please don't have the battery to come into contact with inflammables (e.g. bedside, clothing and books, etc.) since this may result in a fire;
- ◆ Please don't charge the battery in a moist space with high temperature; the temperature is recommended to be 0 ~ 35° C, and the humidity shall not exceed 65%; the design max. ambient temperature for using the product is 45° C;
- ◆ To alleviate the risk of electric shock, children are not allowed to use the product without the help of their parents or other custodians.

III. Product Declaration

- ◆ Please carefully read and observe various instructions and warnings in this manual before using this product. Our company shall not be held responsible for any consequence of failure to properly use this product or observe related operating instructions;
- ◆ This product is suitable for users aged 14 and over. Our company shall not be held responsible for any safety problem arising from the use of this product by too young users or users who are not familiar with relevant safety requirements;
- ◆ As a model in industrial structure, this product is designed exclusively for learning and experience. Do not use this product for other purposes; otherwise, we will assume no responsibility for any consequence thereof;

- ◆ We have been improving the design and operation features of our product, so separate notice will not be given for slight difference between instruction manual and actual product. Hence, any claim for compensation filed based on the data, pictures or text of this instruction manual will be rejected;
- ◆ For constant improvement and sustainable development, our company reserves the right to modify and improve any product detail given in this manual without prior notice;
- ◆ The pictures in instruction manual guide users for operation, and are thus for indication only; the real product shall prevail;
- ◆ Our company and its suppliers shall not be held responsible for any special, incidental, collateral or indirect loss in any case to the greatest extent the law permits, regardless of its cause;
- ◆ Please keep this manual properly since it contains important information.

2

Troubleshooting
P24

3

Commissioning single- cylinder engine
P26

4

Basic structure and features of
single-cylinder engine
P26

5

Basic principle of piston engine
P27

Contents

1

Assembly instructions

P3

- P3. Piston and connecting rod mechanism
- P4. Crankshaft assembly
- P9. Cylinder head assembly
- P11. Camshaft, cylinder block and cylinder head assembly
- P12. Crankcase gear mechanism
- P16. Installation of circuit board
- P18. Generator assembly
- P20. Timing gear
- P22. Guide pulley mechanism

6

Parts list of single-cylinder engine car
P28

Basic knowledge on standard parts assembly

1.Installation of screws

(1) Installation of screws

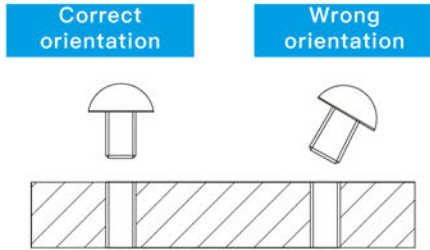

(2)Degree of screw tightening

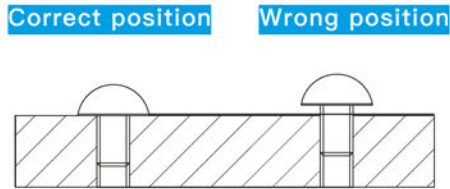

(3)Screw installation order

Mount the screws diagonally in order of number

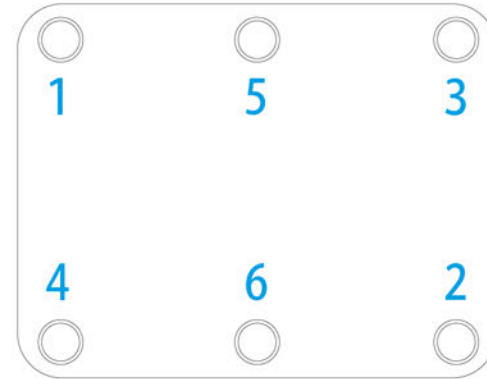

2.Installation of snap ring

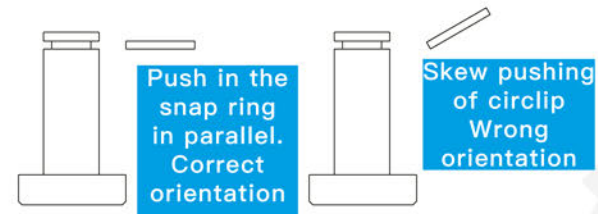

3.Installation of Bearing

(1)Install the bearing into the bearing seat hole

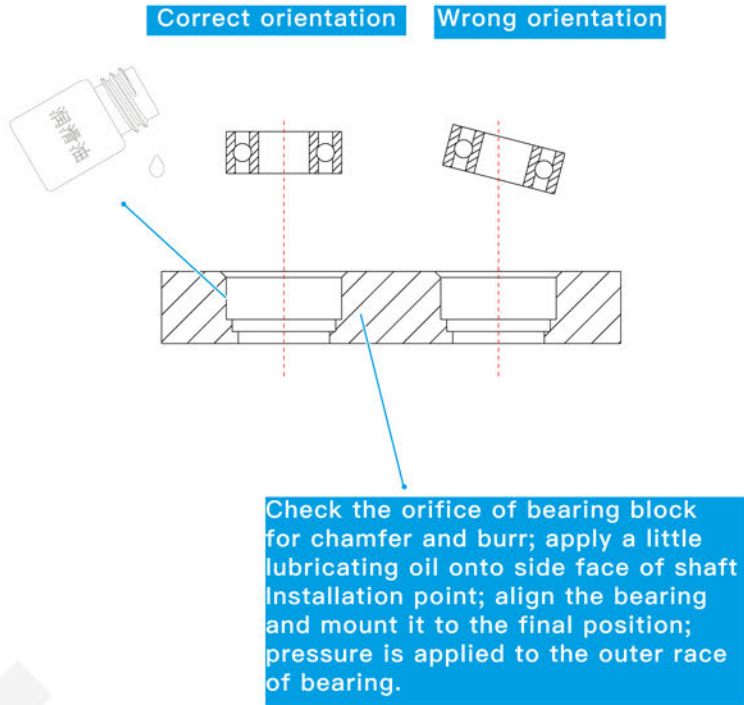

(2) Install the bearing onto the shaft

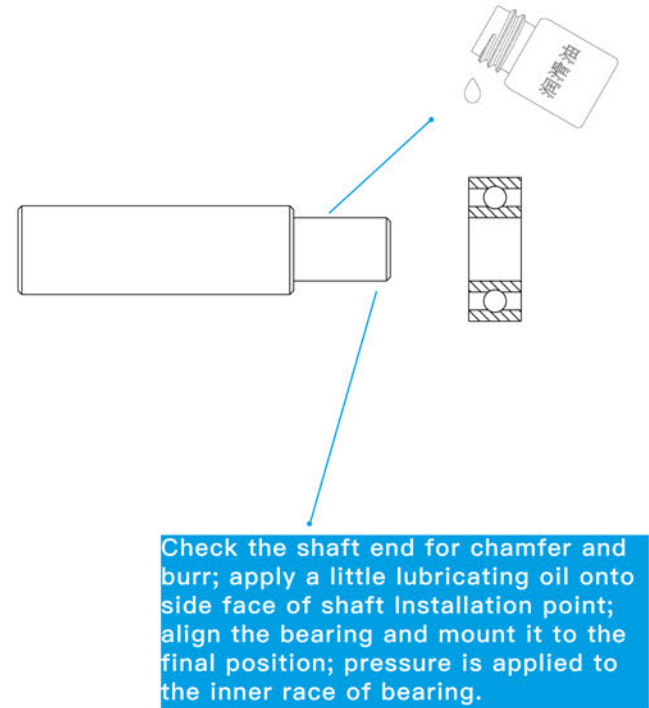

Important note: before assembly, find the bottled lubricating oil, be sure to put enough oil in all the places that need to be lubricated, otherwise the machine is easy to get stuck



Position indicator for lubricating oil

1 Assembly instructions

- 1. Piston and connecting rod mechanism
- 1.1 Connection between piston and connecting rod

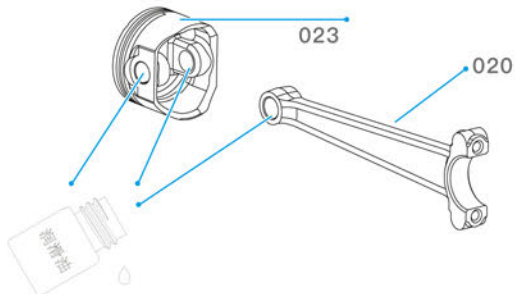

Lubricant(3positions)

1.2 Installation of piston pin

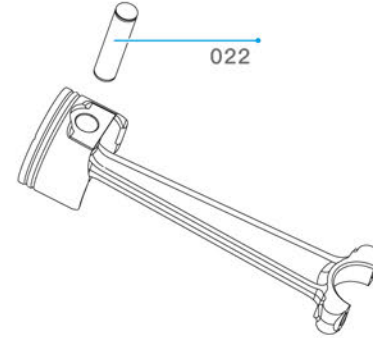

- 1.3 Installation of snap ring
- As shown below, insert the snap rings into the snap ring slots on both ends of the piston pin

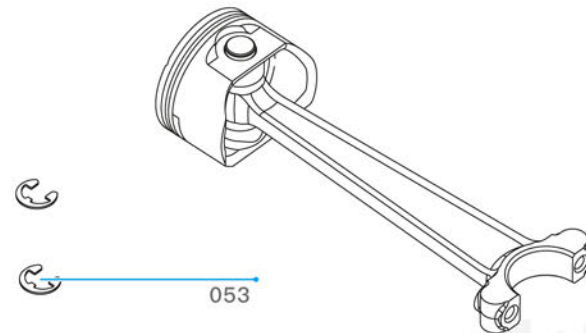

1.4 Installation of connecting rod bearing

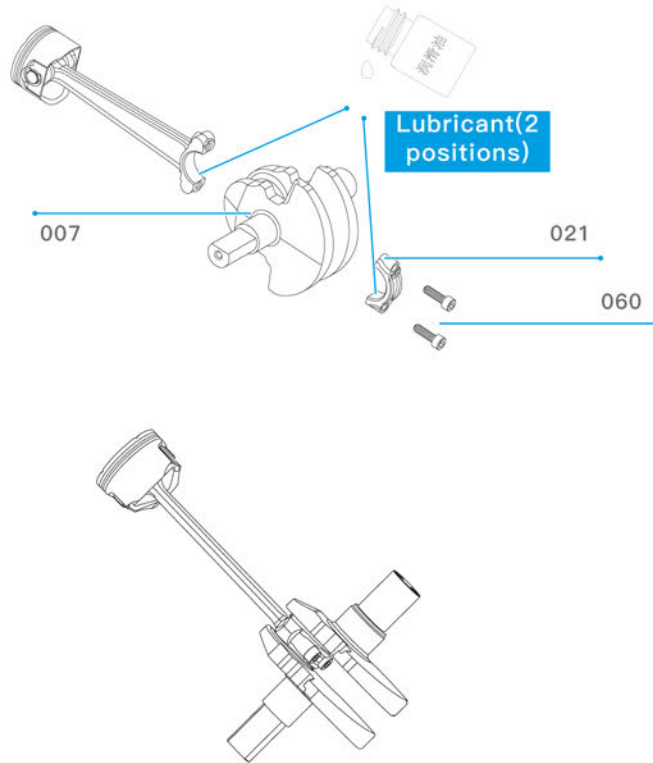

2. Crankshaft assembly

2.1 Assembly of oil pump turbine

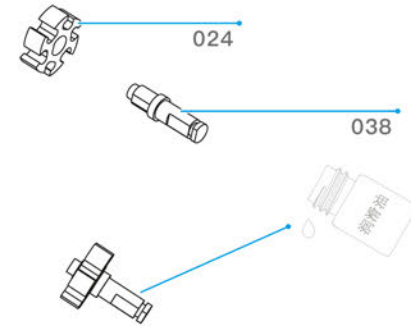

2.2 Connection of oil pump tank

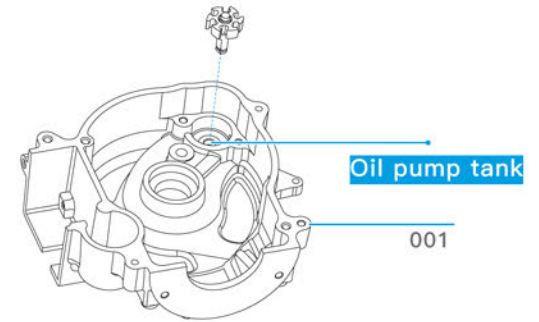

2.3 Installation of end cap of oil pump

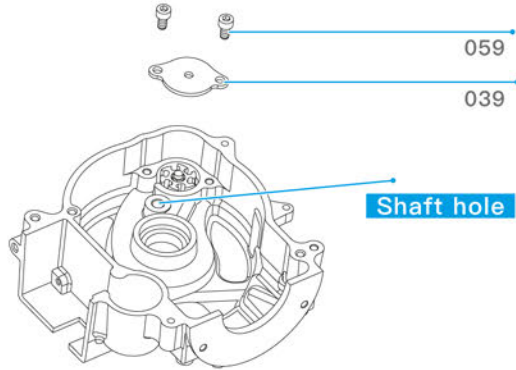

2.4 Installation of carrier gear shaft

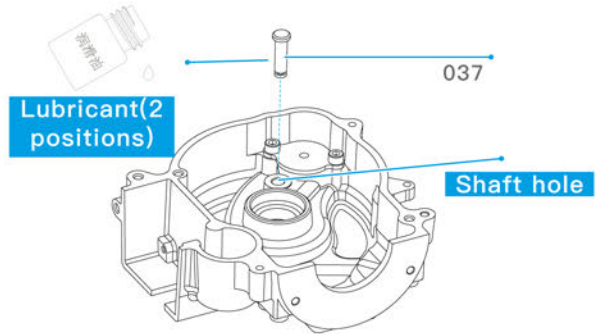

2.5 Installation of carrier gear and oil pump gear

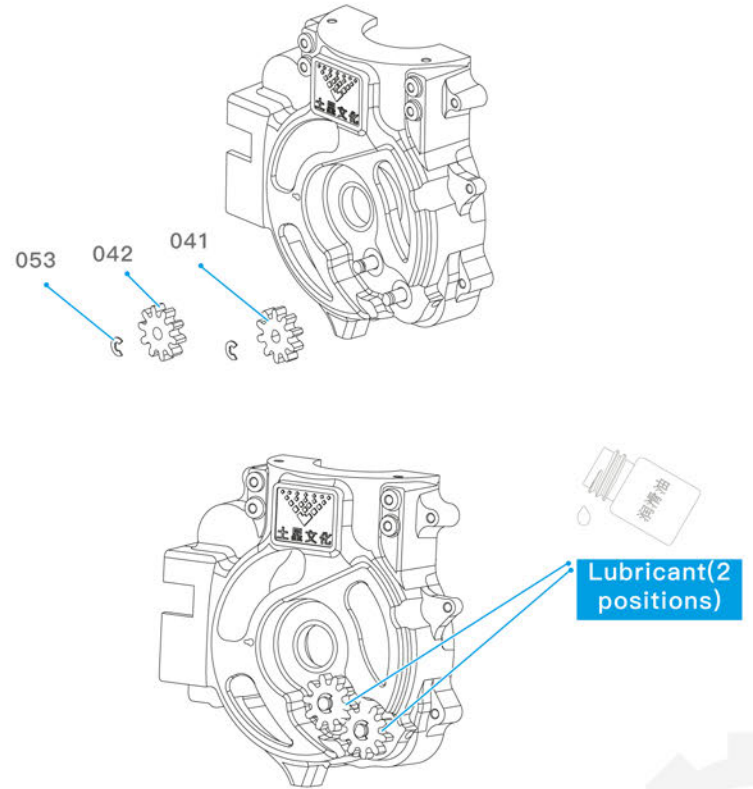

2.6 Installation of starting motor

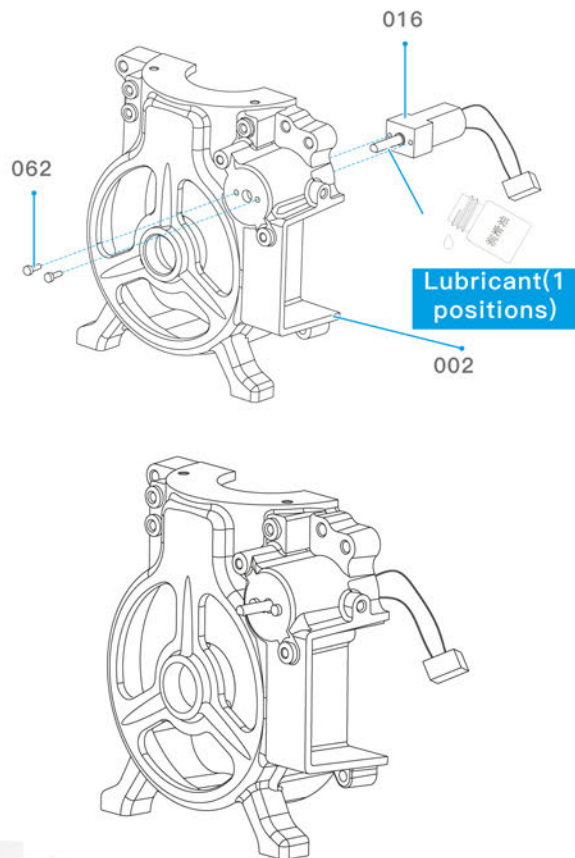

2.7 The crankshaft butted with the back cover of the crankcase

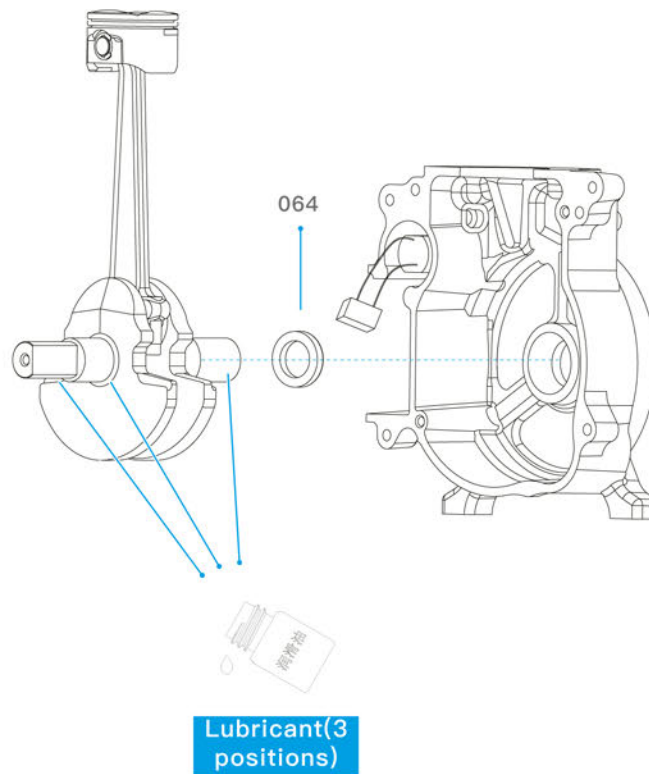

2.8 Installation of locating pin

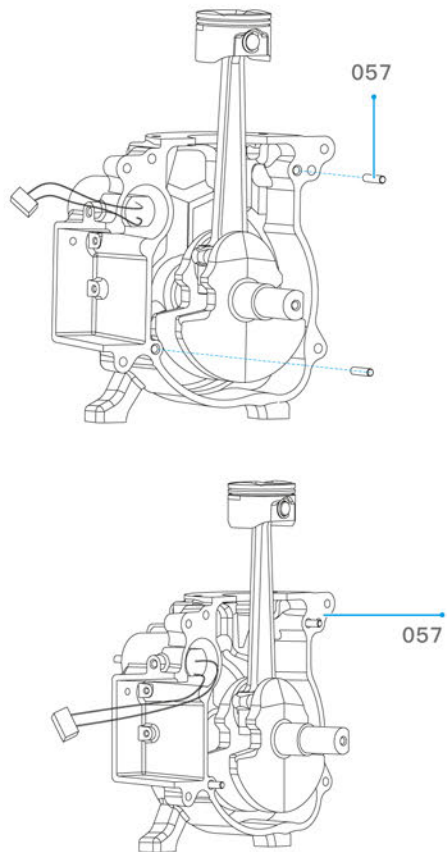

2.9 Assembly of crankcase

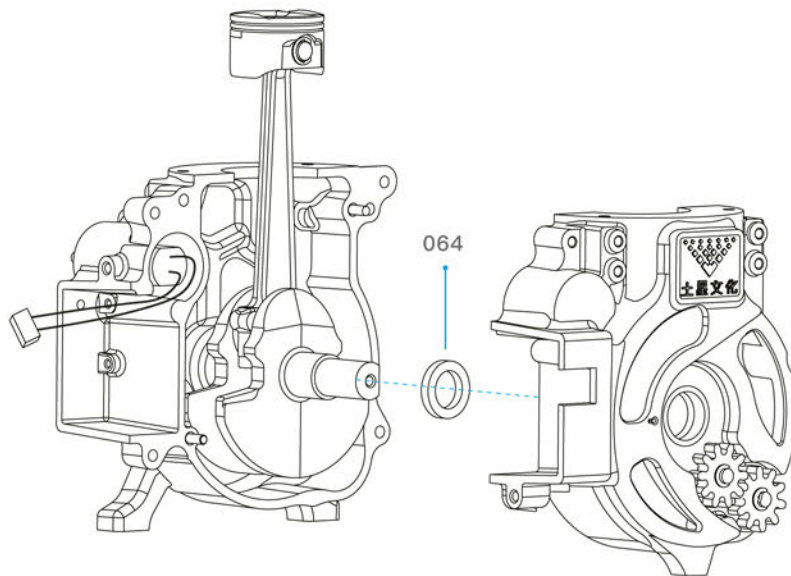

2.10 Installation of link screw

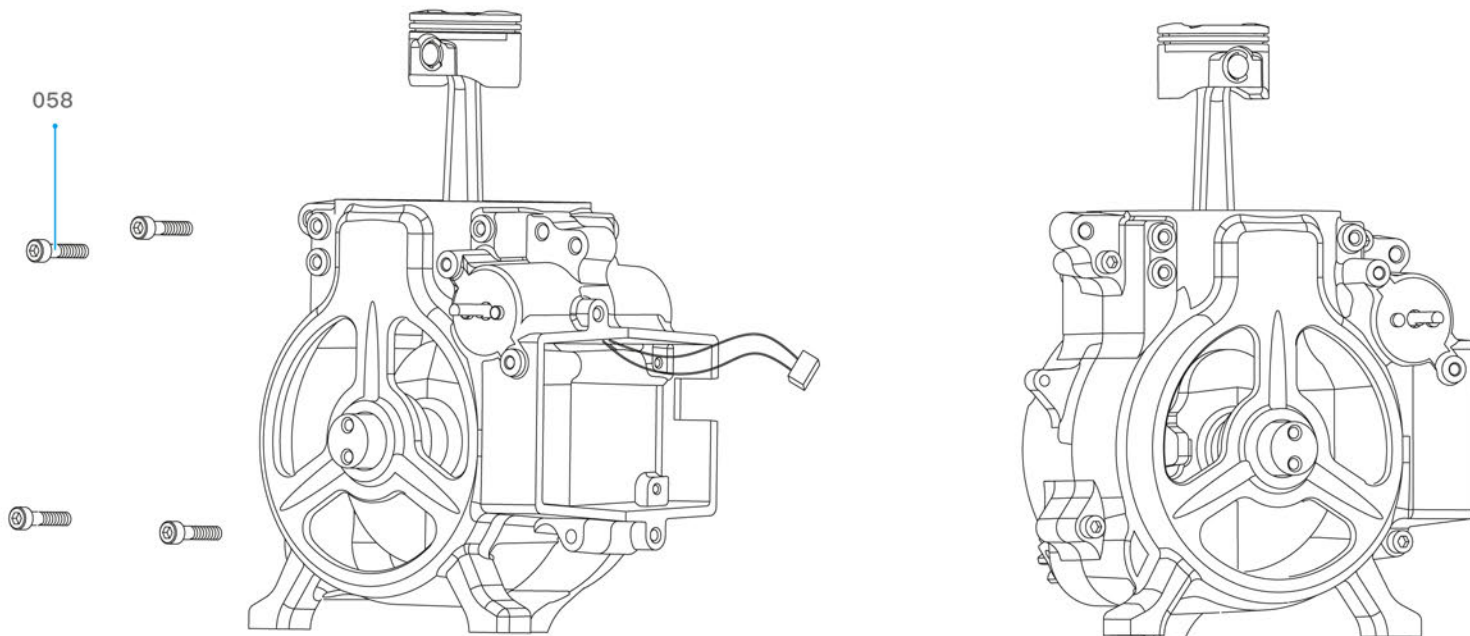

3 Cylinder head assembly

3.1 Installation of valves

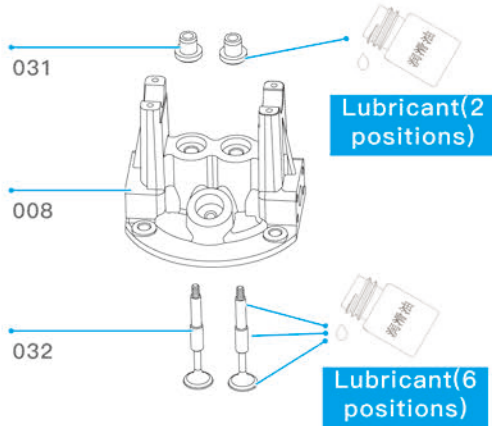

3.2 Installation of valve springs and valve caps

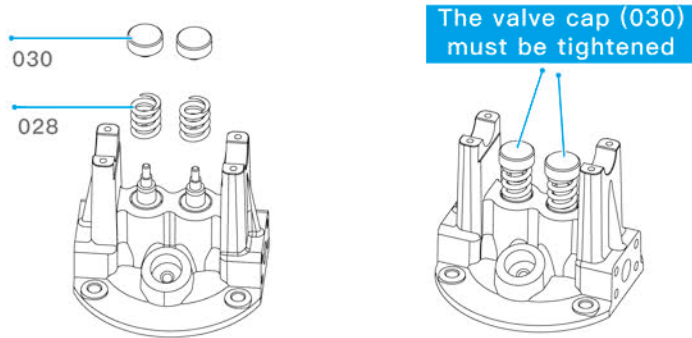

3.3 Installation of spark plug

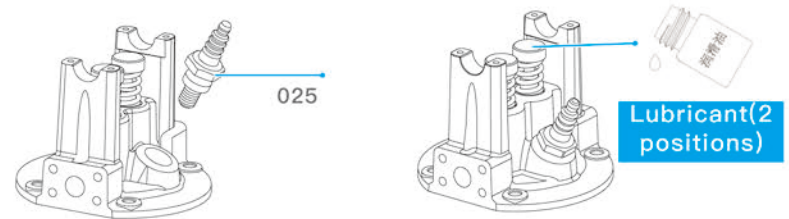

3.4 Assemble cam synchronous wheel

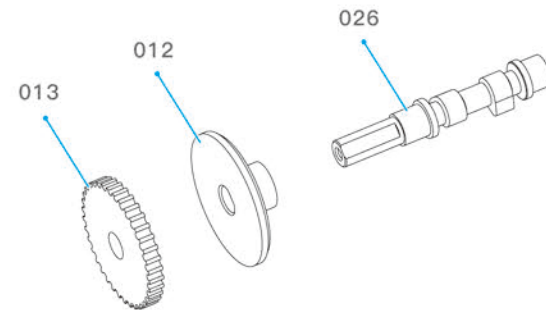

3.5 Fixation of Synchronous wheel

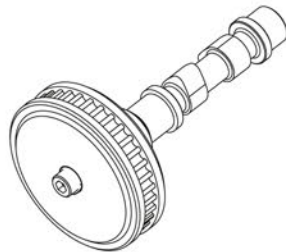
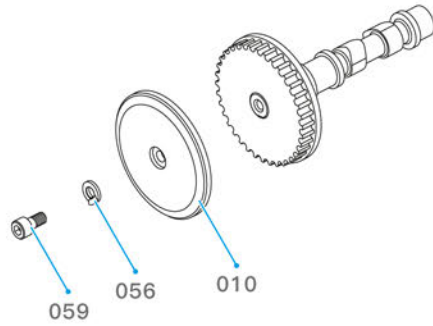

3.6 Connection of camshaft and cylinder head

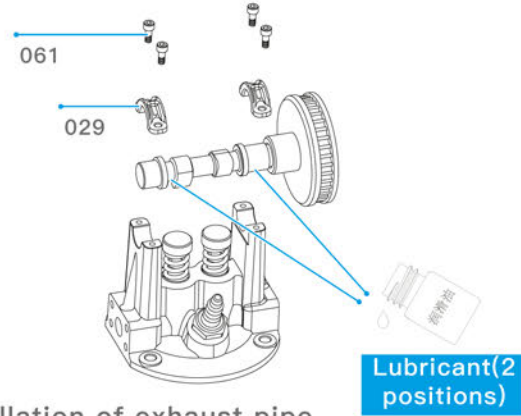

3.7 Installation of exhaust pipe

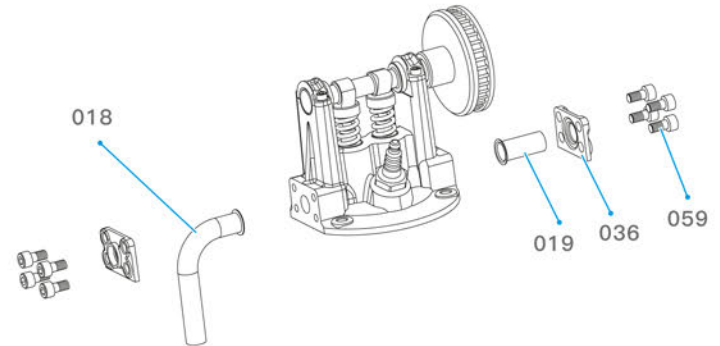

4 Camshaft, cylinder block and cylinder head assembly

4.1 Installation of cylinder block

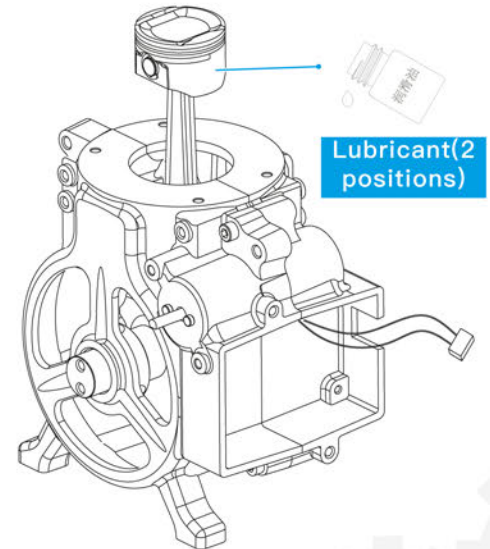
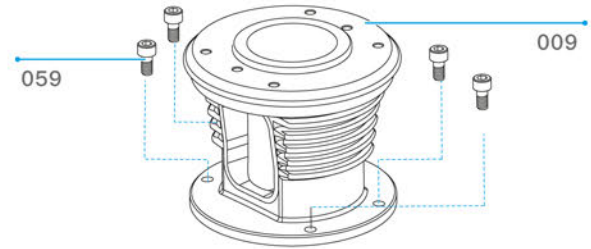
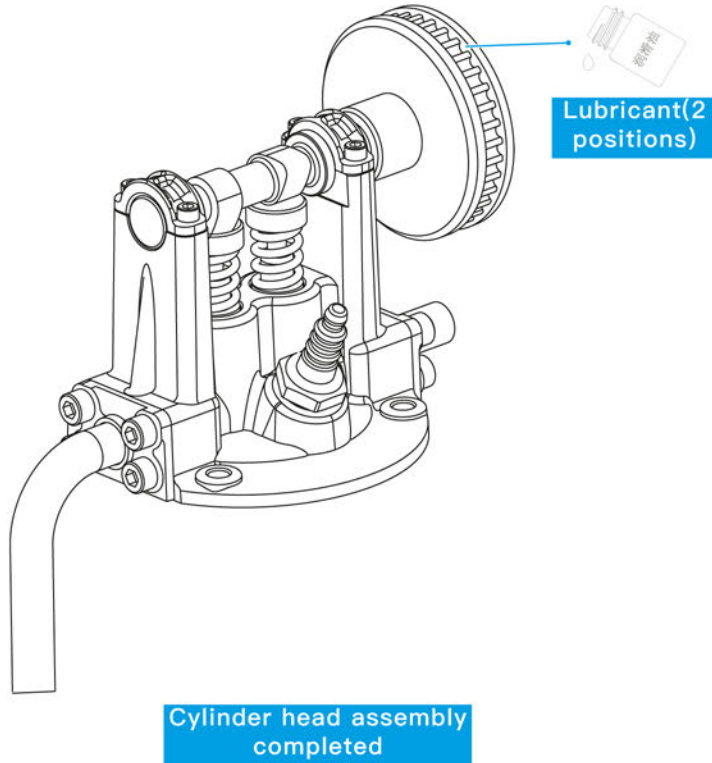

4.2 Connection of cylinder head assembly

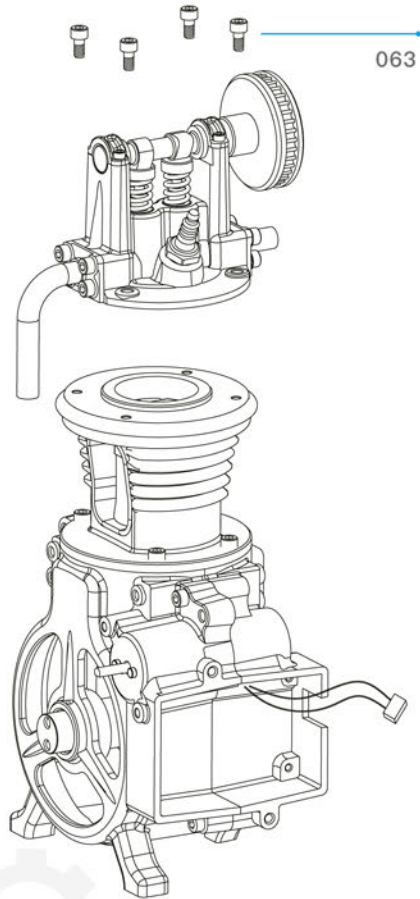

5 Crankcase gear mechanism

5.1 Installation of crankshaft gear

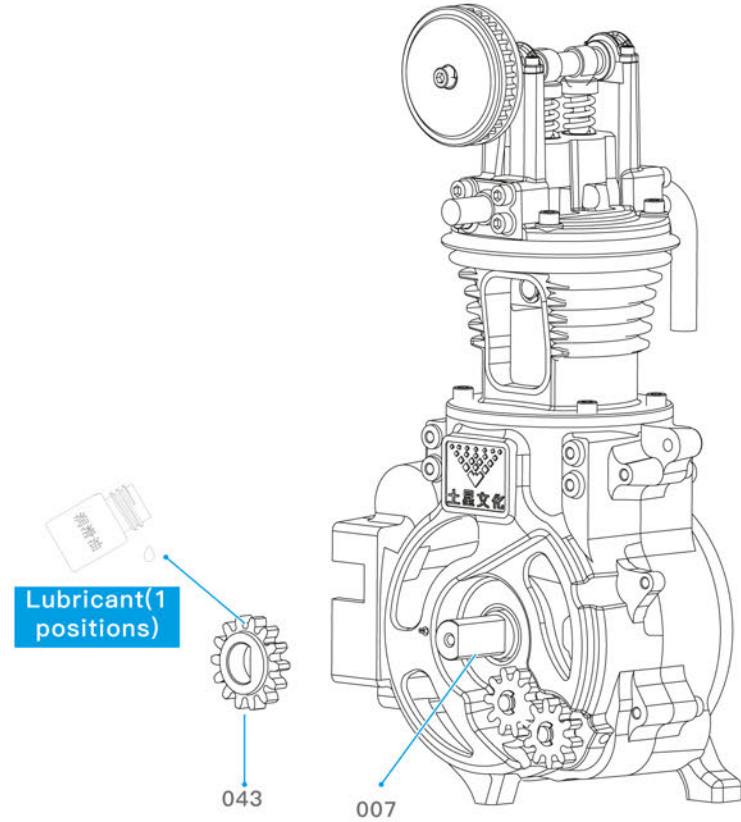

5.2 Installation of crankshaft pulley

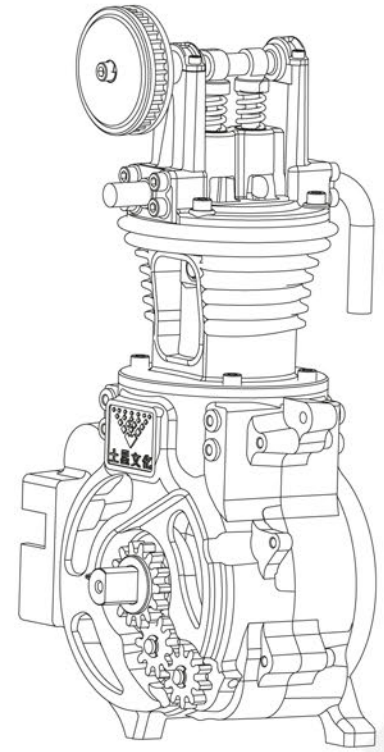
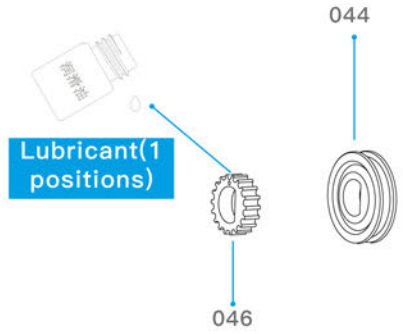
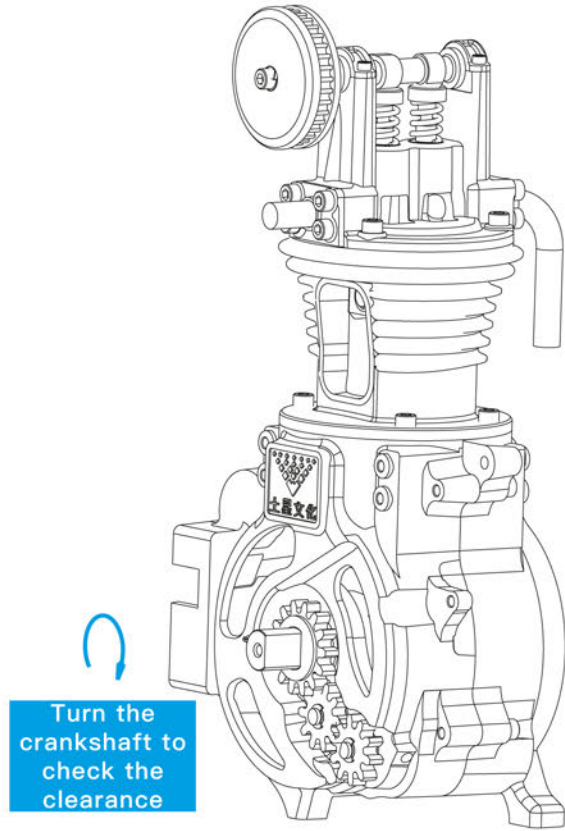

5.3 Installation of crankshaft timing base and crankshaft cap

5.4 Installation of flywheel

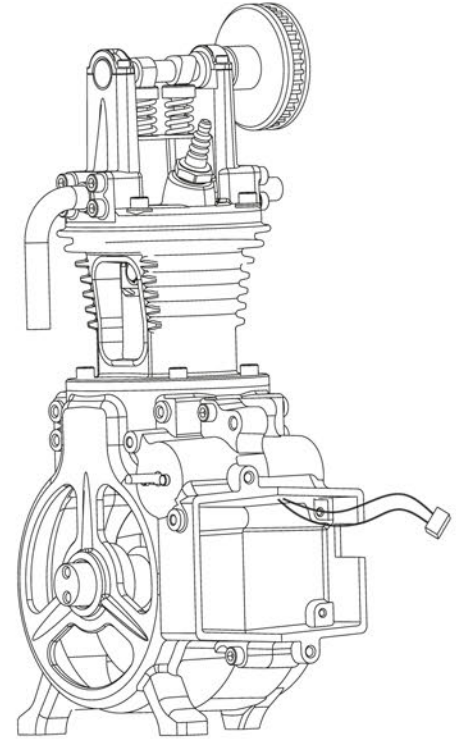
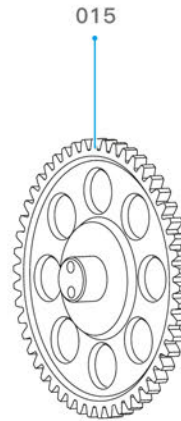
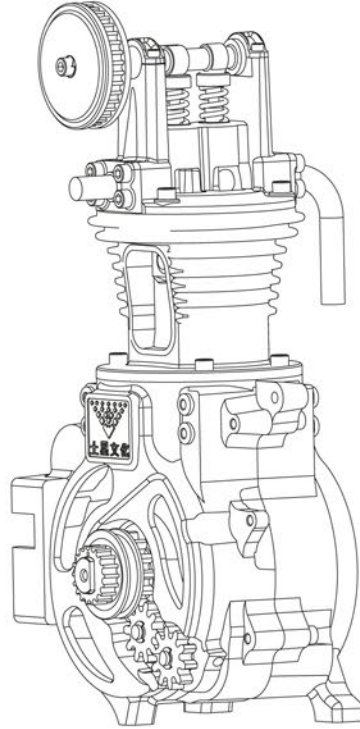
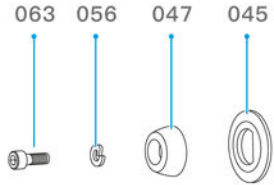

5.5 Installation of starting gear and gear cover

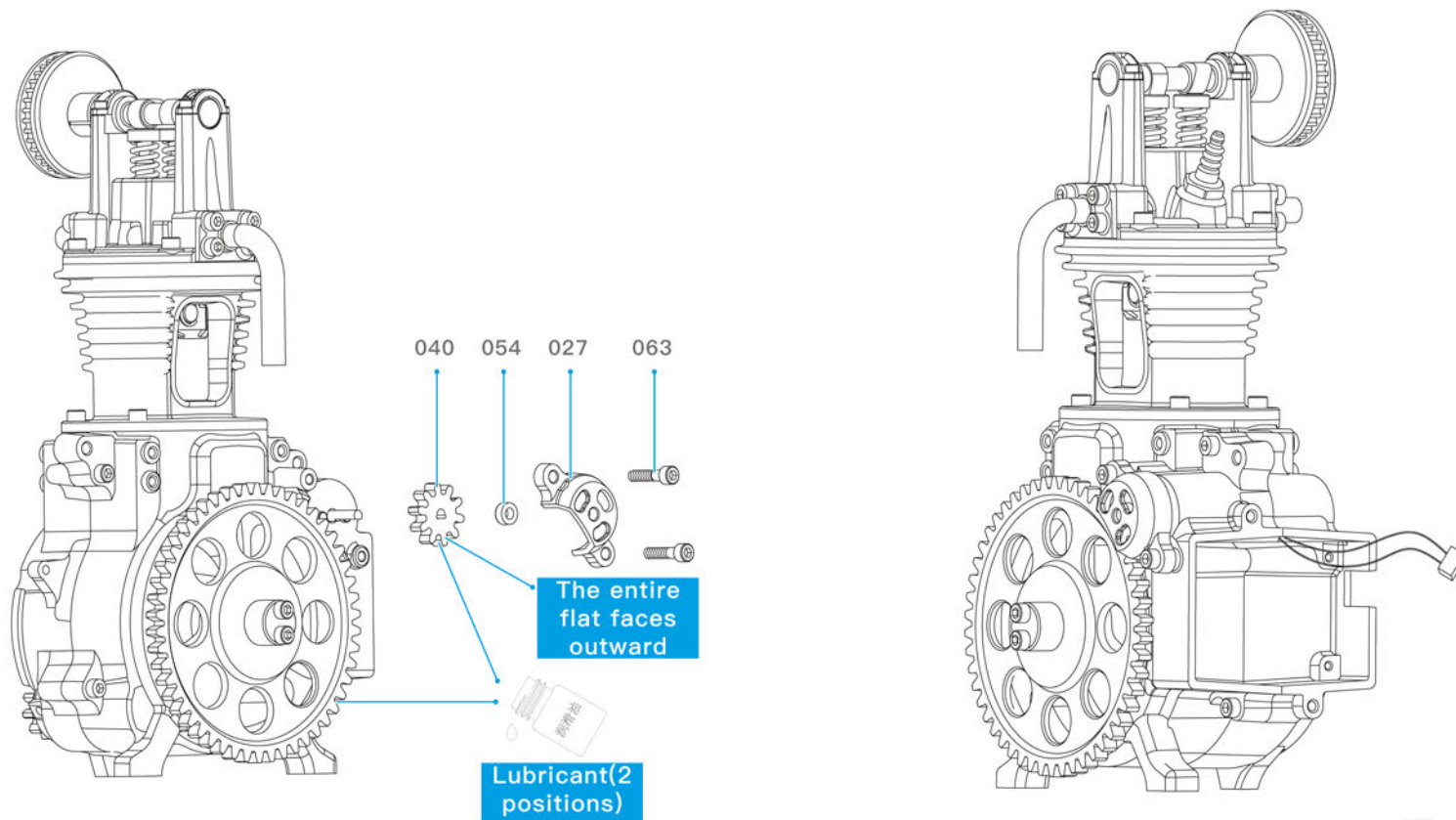

6. Installation of circuit board

6.1 Installation of circuit board

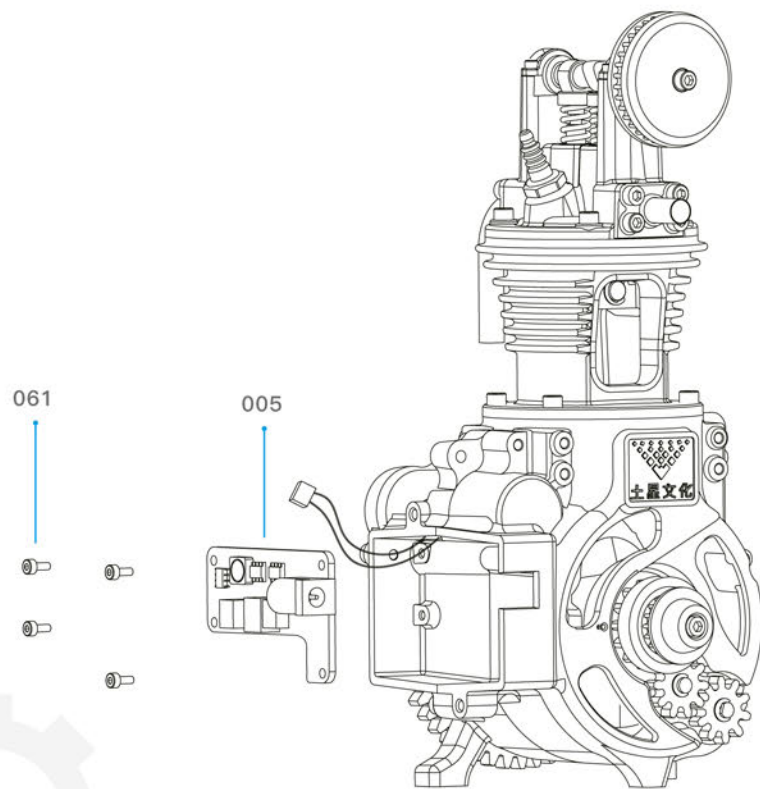

6.2 Installation of battery

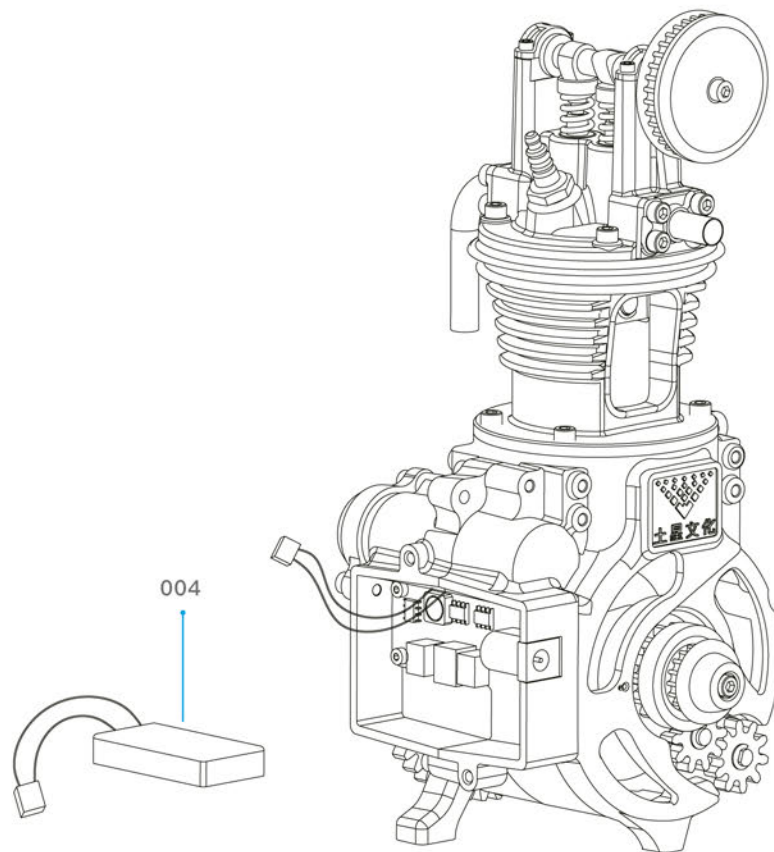

6.3 Wiring of Circuit Board

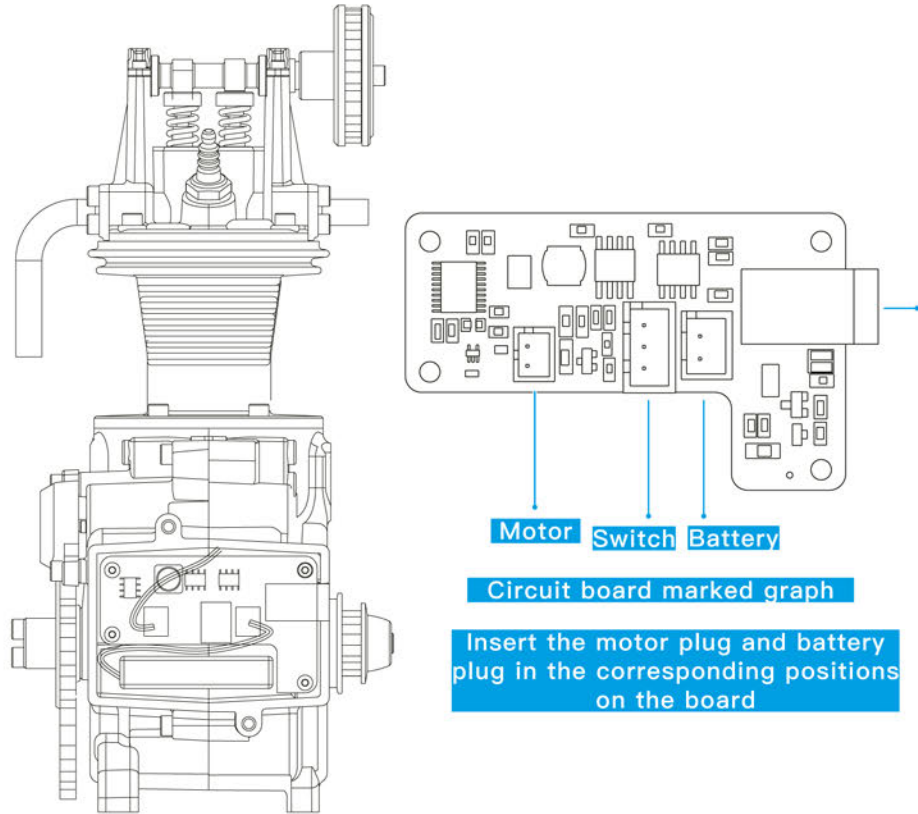

6.4 Switch Installation

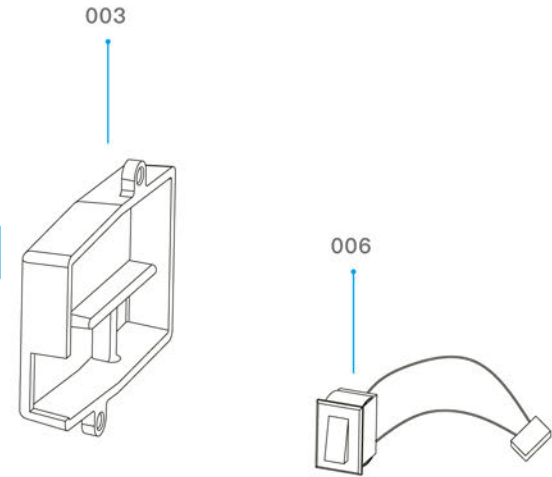

6.5 Installation of battery cover

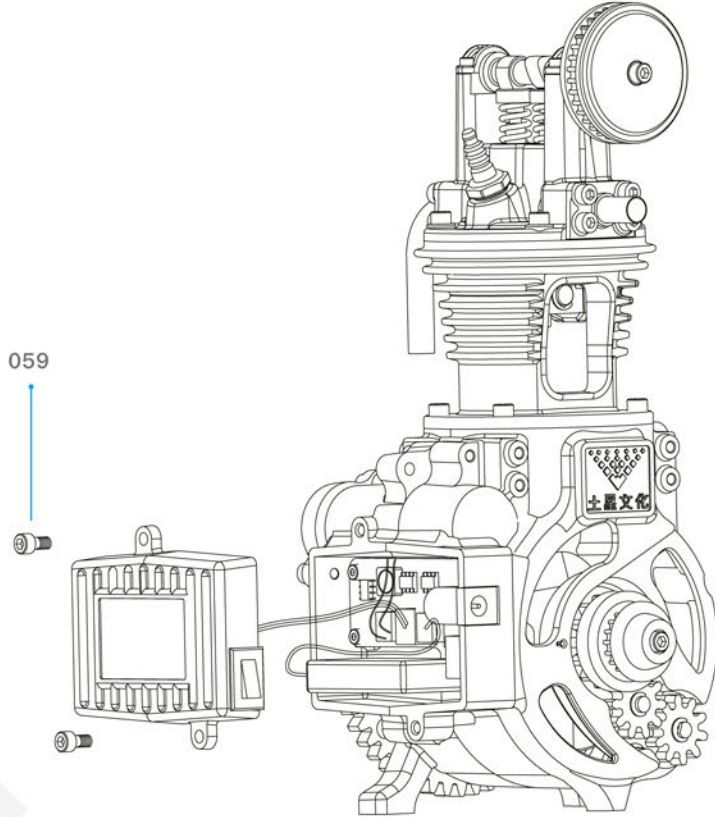

The power plug must be plugged into the board first, then install the screws.

7. Generator assembly

7.1 Generator assembly

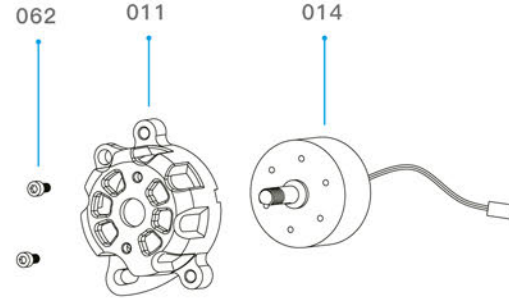

7.2 Assembly of generator front and rear covers

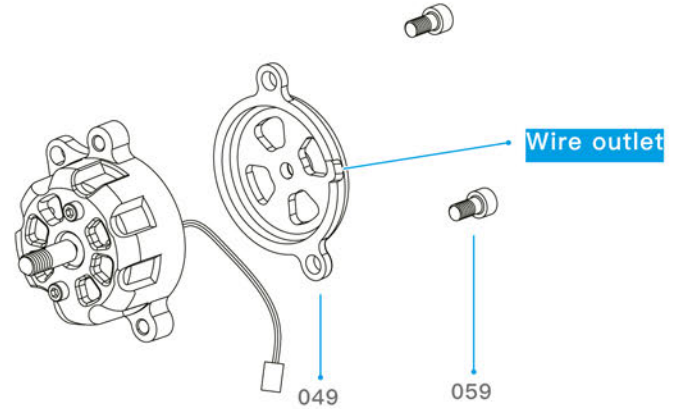

7.3 Installation of pulley

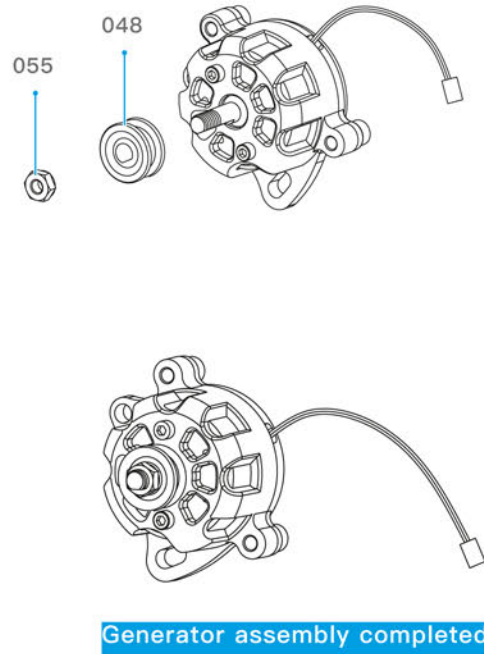

7.4 Combination of Generator Assembly and Crankcase

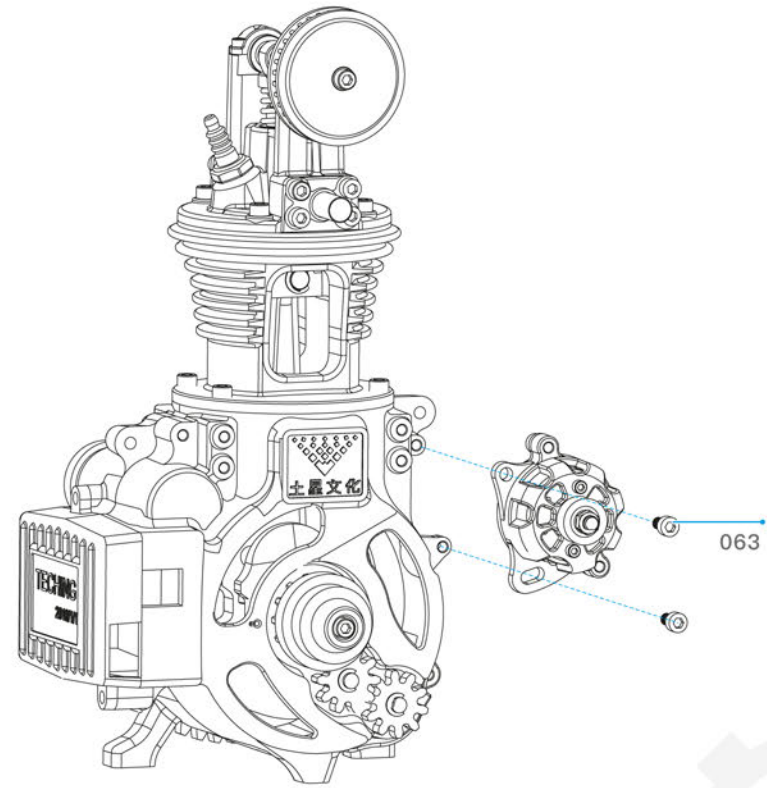

7.5 Installation of generator belt

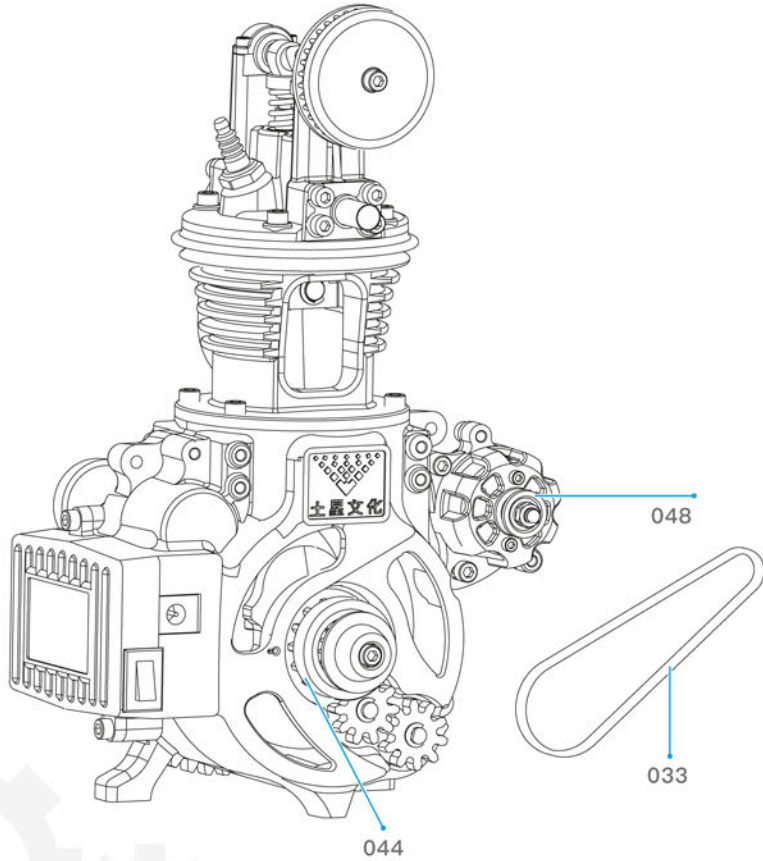

8 Timing gear

8.1 Removal of crankshaft synchronizer

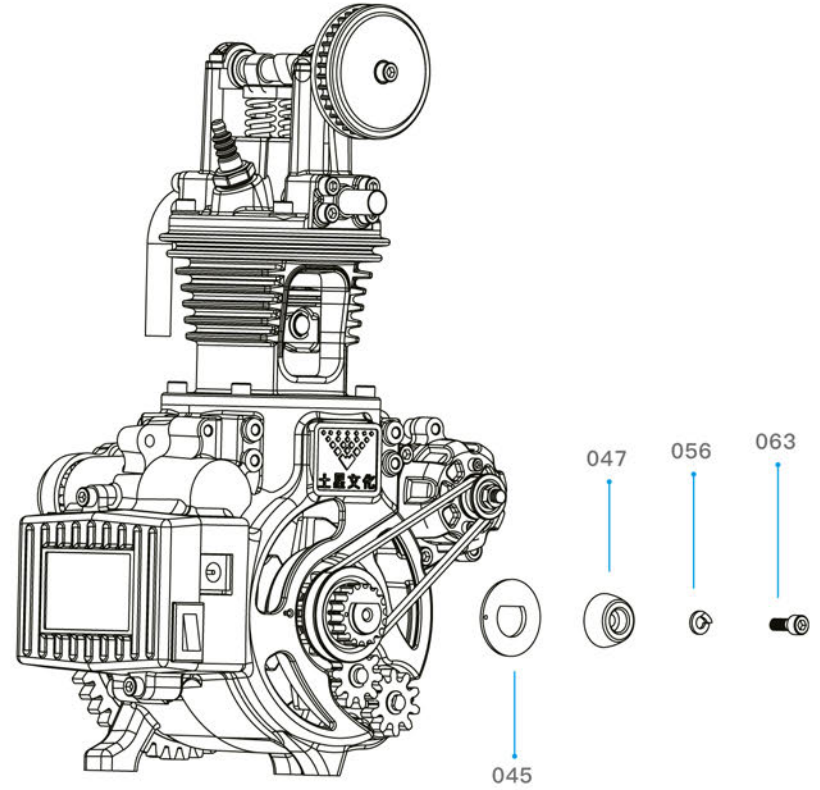

8.2 Timing Alignment and Installation of Timing Belt

Centerline of axle bush

Cam sync base scale mark

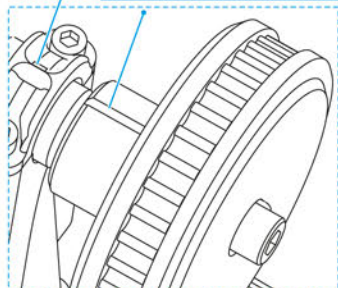

A

A: Rotate the cam sync base to align its scale mark with center line of axle bush.
B: Rotate the single-cylinder crankshaft (or flywheel) in such a manner that the timing point of crankshaft timing pulley is aligned with the timing point on front cover of crankcase. Then, arrange the timing belt after assuring the alignment of points A and B.

Timing point at front cover of crankcase

Timing point of crankshaft timing pulley

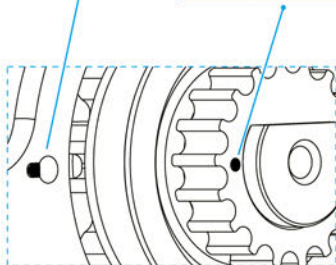

B

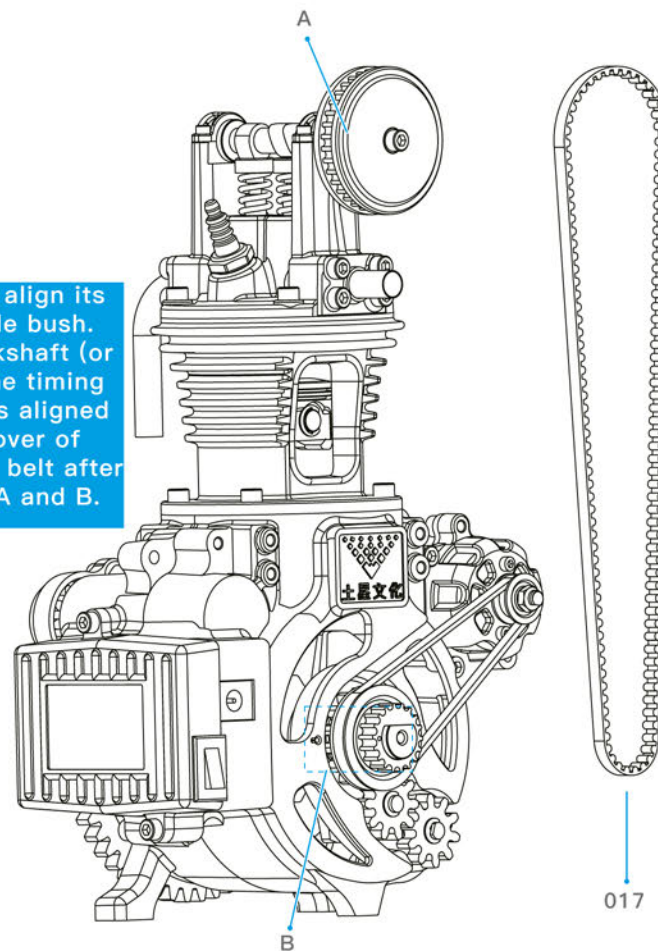

8.3 Installation of crankshaft timing base and crankshaft cap

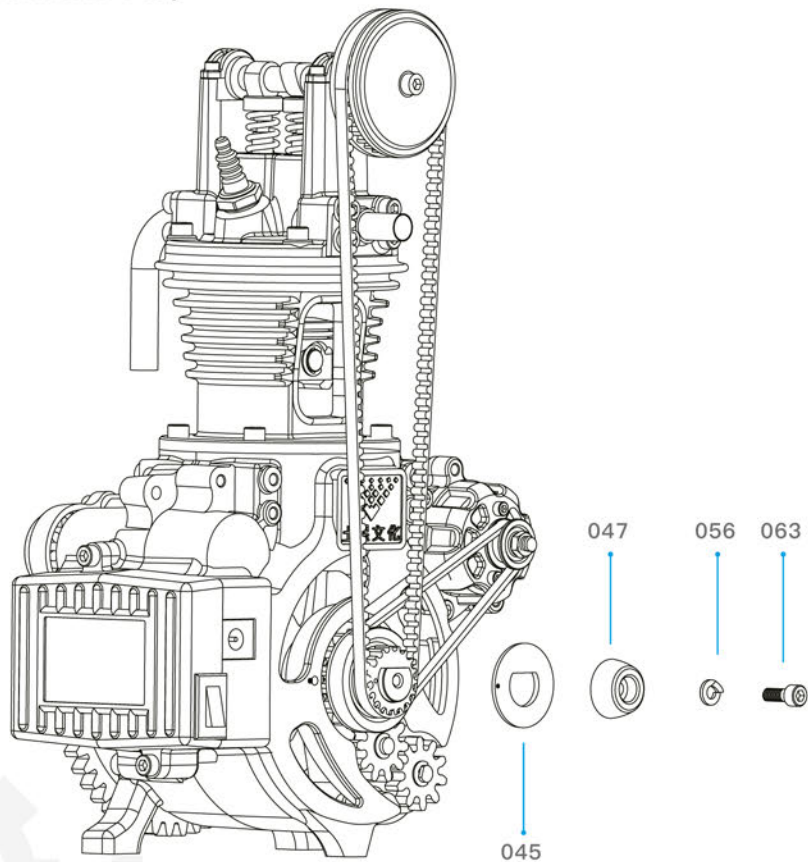

9 Guide wheel mechanism

9.1 Assembly of guide wheel assembly

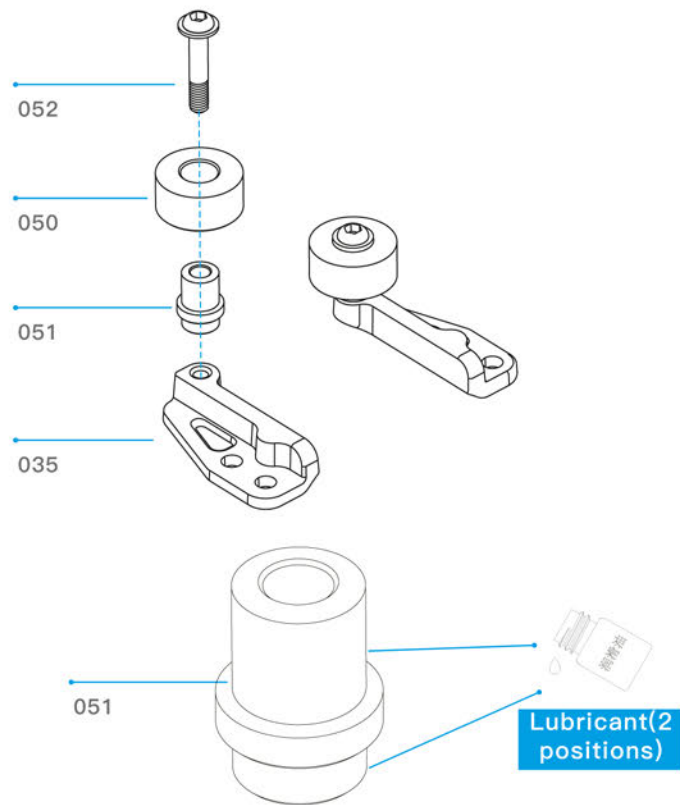

9.2 Charging state

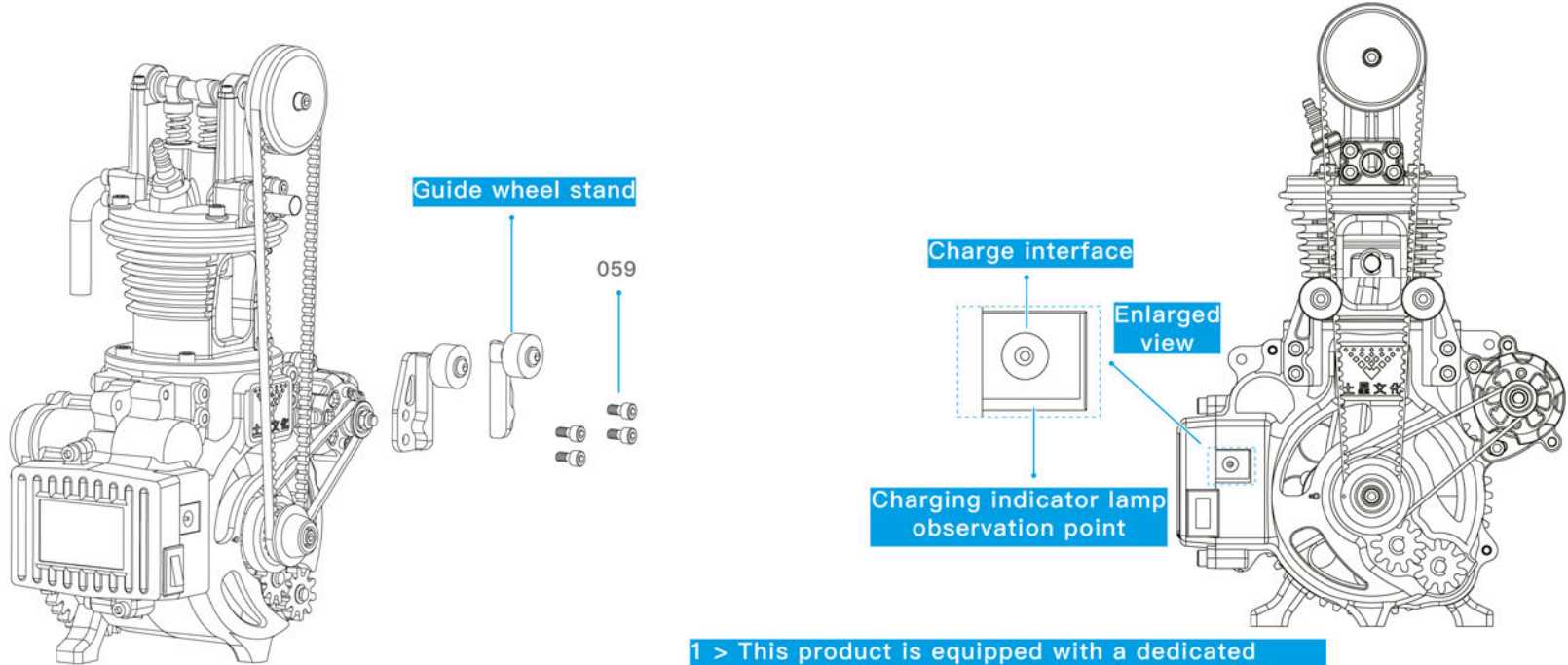

- 1 > This product is equipped with a dedicated charging cable. User-supplied power adapter, Its output DC voltage needs 5V, and its output DC current is not less than 1000mA. Do not use an adapter higher than 6V to charge the product;
- 2 > For other precautions, please refer to the second item in the "Notes" section of this manual;
- 3>Normal charging state:
- ◇ the red lamp is ON during charging;
 - ◇ the blue lamp is ON when fully charged;
 - ◇ the max. charging time is 2h.

2 Troubleshooting

After assembly, open the switch to check if the movement is abnormal; first check whether the relevant moving parts are coated with lubricating oil as shown in the figure, and then check the assembly sequence one by one according to the instructions; if no problem is found, please follow the steps below to find the problem and solve it.

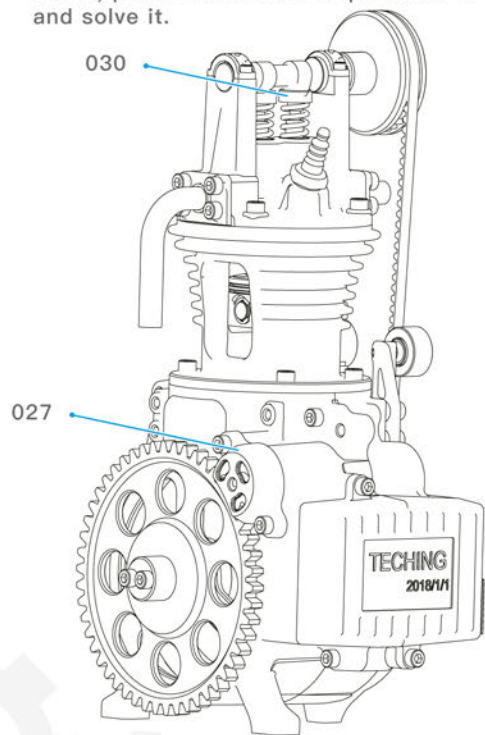

- 1> Is the part installed in the correct direction?
- 2> Check whether the screws are too tight or too loose.
- 3> Check if similar parts are installed in reverse
- 4> If there is motion abnormality, loosen the 027 gear cover fixing screw one turn, then start the motor to check if it is normal. Then check if the 040 starter gear is reversed or the 054 motor sleeve is missing.
- 5> Check the 030 valve cap for loosening, if so, tighten it.

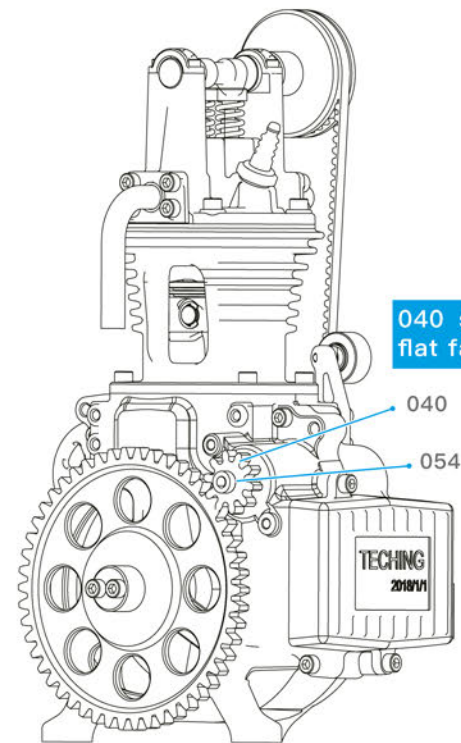

二 > Electronic troubleshooting

1 Charging failure

① Charger does not match

Solution:

Charge the product with a standard USB charger. The charger requires an output of 5V 1A (inclusive) or more. Use the USB head of TECHING's dedicated charging cable to plug into the USB port of the phone charger. Plug the round plug into the charging port of the product and charge it. As shown in Figure 1-1.

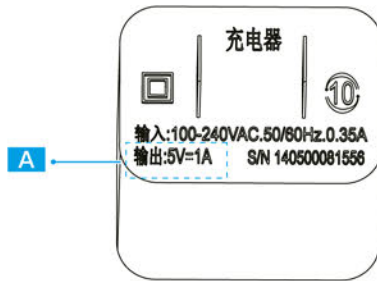

Figure1-1

输出: 5V=1A

A

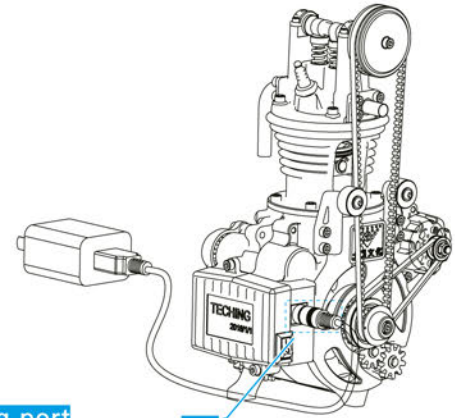
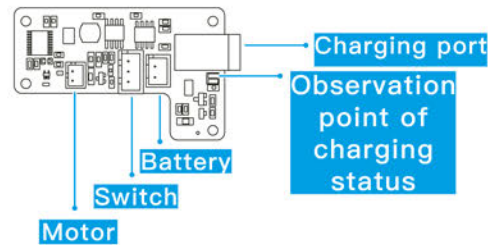
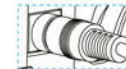

Figure1-2



Observation
point of
charging
status

② Charging cable round plug is not inserted into the end

Solution:

Check whether the circular plug of the special charging line of TECHING and the round hole of the charging port are inserted into the end. As shown in Figure 1-2.

③ Check charge status

Solution:

Remove the bottom shell of the circuit board, and then charge the product. Observe the charging light on the circuit board (No. 005). The red light is on when charging, and the blue light is on when fully charged. As shown in Figure 1-3

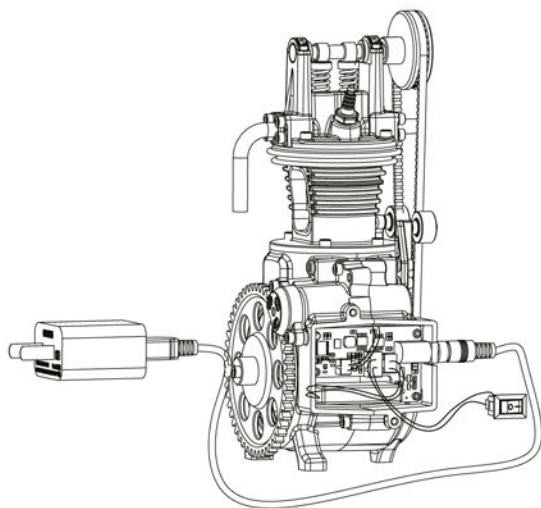
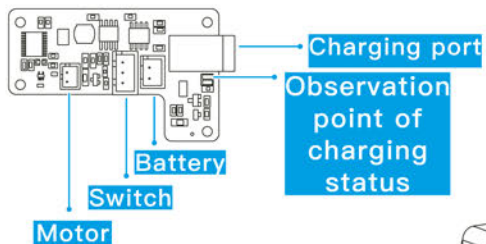

Figure 1-3



2 The motor does not work

① The battery is dead

Solution:

Use TECHING's dedicated charging cable to plug into the computer's USB port or the USB port of the mobile phone charger to charge the product. The red light is on when charging, and the blue light is on when fully charged. After fully charging, turn the power switch on and check if the motor can run normally. As shown in Figure 2-1

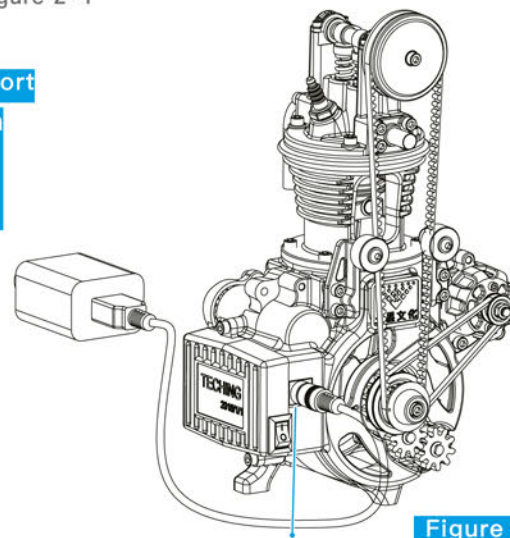

Observation point of charging status

② Motor troubleshooting

Solution:

Remove the start gear of the motor and test whether the motor can run smoothly. As shown in Figure 2-2. Note: If it can run smoothly, check the mechanical part reason according to the mechanical troubleshooting method.

If the motor still does not work, please consult our after-sales support or return to factory for repair.

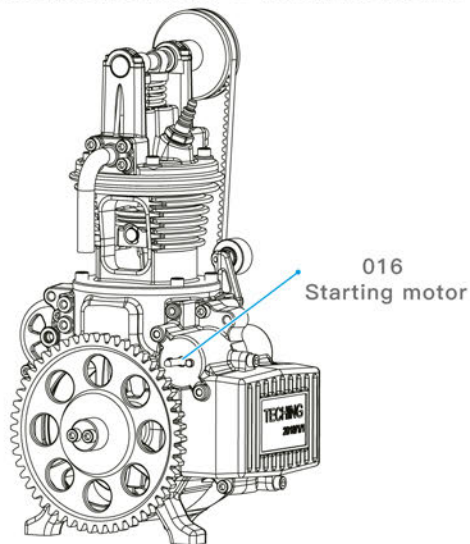
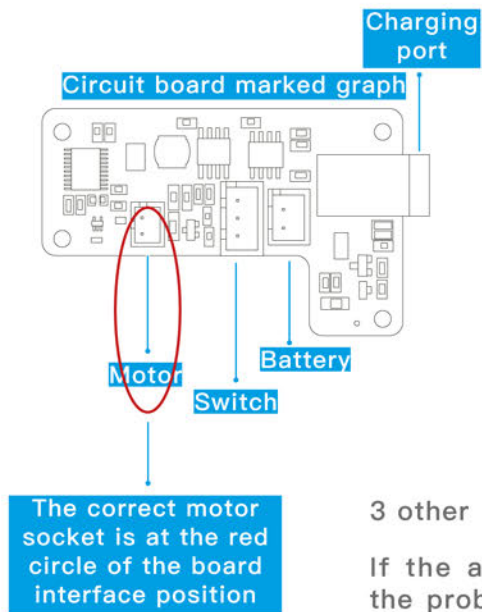

Figure 2-2



③ Motor (serial number 016) plug is inserted in the wrong position

Solution:

Check if the motor (serial number 016) is in the correct position (Please refer to page 17 of the manual for details); as shown in Figure 2-3

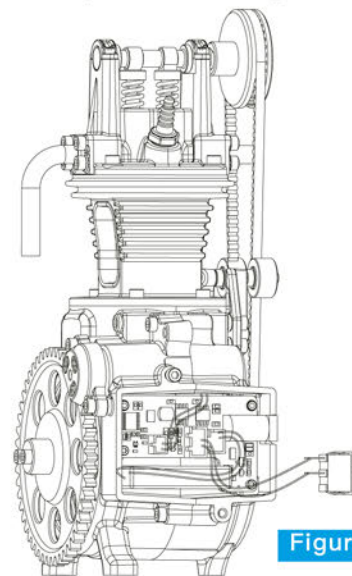

3 other

If the above solutions can not solve the problem, please consult Our after-sales support or return to factory for repair.

3 Adjustment of single-cylinder engine

1. Fitting clearances

Pay attention to fitting clearances among moving parts. The user is encouraged to adjust clearances slightly using, for example, sandpaper and calipers, based on his/her own observations and judgments.

The main parts are as follows:

- 1.1 Crankshaft and related moving parts
- 1.2 Camshaft and related moving parts
- 1.3 Starting motor and related moving parts
- 1.4 Piston rod and related moving parts

2. Lubrication

Since this product is a metallic mechanical model, the absence of lubricant for shaft movement may result in higher frictions or even seizure of parts during movement. The user is encouraged to apply appropriately more lubricant at shaft assembly positions, and observe the effect after lubricant application.

3. Noise reduction

Shaft moving parts are made of aluminum alloy and have anodized surfaces, and there are loose clearances among some parts, so this product may produce high noise when newly assembled. The user is encouraged to observe and analyze noise producing positions, and may also repair with such tools as sandpaper and file, and apply lubricant to observe the noise reduction effect.

4 Basic structure and features of single-cylinder engine

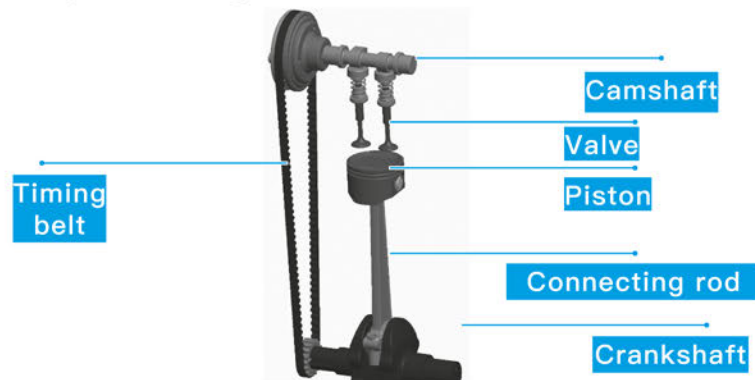

Compared to multi-cylinder engines with the same displacement, a single-cylinder engine works on a set of machine parts only, so the inertial force of the moving parts cannot be offset, resulting in high vibration. This is especially true as speed rises. In addition, the moving parts of a single-cylinder engine are relatively larger, which is adverse to speed increase, and is especially true as displacement rises. Therefore, the larger the displacement of a single-cylinder engine is, the lower power per liter will be, but the stronger pulsing will be. Since single-cylinder engines are simple in structure, they are characterized by light weight and small size as compared to multi-cylinder engines with the same displacement, so a single-cylinder engine helps reduce overall weight and improve overall operating flexibility. When an engine is in a transversal arrangement, the gyroscopic effect of the rotating crankshaft will prevent the motorcycle from tilting laterally to turn; the heavier the crankshaft is, the greater such resistance will be. Since a single-cylinder engine has a short crankshaft, its gyroscopic effect is much weaker, it can tilt laterally leftward or rightward easily, and the driver will feel that the steering handle is very light. Due to the above features of single-cylinder engines, off-road motorcycles with a displacement of 250CC mostly use single-cylinder engines, as do super-sport motorcycles. Among ordinary motorcycles, small ones with a displacement of below 125CC usually use single-cylinder engines.







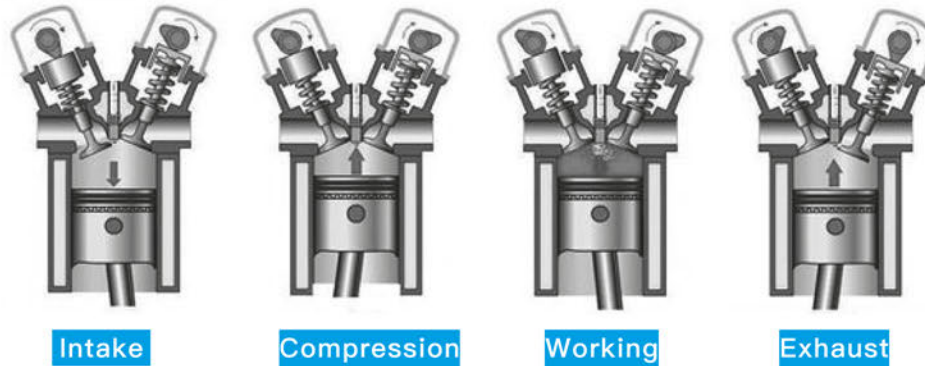

5 Basic principle of piston engine









1. Piston moving down → taking in air and gasoline;
2. Piston moving up → compressing the mixture;
3. Piston moving down → igniting the compressed gas; which burns and expands to drive the piston;
4. Piston moving up → discharging exhaust gas









As shown below:



















When the single-cylinder engine is working, for every two turns of the crankshaft, the piston makes 4 straight-line reciprocating motions in the cylinder to complete a working procedure (4 strokes), the mixture in the cylinder is ignited, and the bursting gas pushes the piston to make the crankshaft rotate via the crankshaft connecting rod, realizing the straight-line reciprocating motion of the piston in the cylinder. The continuous vertical motion of the piston turns into the continuous rotary motion of the crankshaft to output power continuously and make the engine run normally.









No.	Product picture	Product name	Qty.
001		Front cover of crankcase	1
002		Rear cover of crankcase	1
003		Battery cover	1
004		Battery	1
005		Circuit board	1
006		Switch	1
007		Single cylinder crankshaft	1
008		Cylinder head	1

No.	Product picture	Product name	Qty.
009		Cylinder block	1
010		Cam synchronizing cover	1
011		Generator front cover	1
012		Cam synchronizing base	1
013		Cam synchronizing wheel	1
014		Generator	1
015		Flywheel	1
016		Starting motor	1

No.	Product picture	Product name	Qty.
017		synchronous belt	1
018		Intake pipe	1
019		Exhaust pipe	1
020		Crankshaft connecting rod	1
021		Connecting rod bearing	1
022		Piston pin	1
023		Piston	1
024		Oil pump turbine	1

No.	Product picture	Product name	Qty.
025		Spark plug	1
026		Camshaft	1
027		Gear cover	1
028		Valve spring	2
029		Camshaft cover	2
030		Valve cap	2
031		Valve cover	2
032		Valve	2

No.	Product picture	Product name	Qty.
033		Generator belt	1
034		Guide wheel stand (right)	1
035		Guide wheel stand (left)	1
036		Pipe fixing base	2
037		Carrier gear shaft	1
038		Turbine shaft	1
039		End cap of oil pump	1
040		Starter gear	1

No.	Product picture	Product name	Qty.
041		Oil pump gear	1
042		Transitional gear	1
043		Crankshaft gear	1
044		Crankshaft pulley	1
045		Crankshaft timing base	1
046		Crankshaft timing pulley	1
047		Crankshaft cap	1
048		Generator pulley	1

No.	Product picture	Product name	Qty.
049		Generator rear cover	1
050		Guide wheel	2
051		Guide wheel shaft	2
052		M3X16	2
053		M3 Snap spring	4
054		Motor casing	1
055		M4 nut	1
056		M3spring washer	2

No.	Product picture	Product name	Qty.
057		Locating pin	2
058		M3X12	6
059		M3X6	25
060		M3X10	2
061		M2X5	8
062		M1.6X4	4
063		M3X8	9
064		Bearing 18X12X4	2